

# 11 Cylindrical roller thrust bearings

<b>Designs and variants</b> .....	<b>879</b>
Single direction bearings .....	879
Double direction bearings.....	879
Cylindrical roller and cage thrust assemblies.....	880
Bearing washers.....	880
Cages.....	881
<b>Bearing data</b> .....	<b>881</b>
(Dimension standards, tolerances, permissible misalignment)	
<b>Loads</b> .....	<b>884</b>
(Minimum load, equivalent dynamic bearing load, equivalent static bearing load)	
<b>Temperature limits</b> .....	<b>884</b>
<b>Permissible speed</b> .....	<b>884</b>
<b>Design considerations</b> .....	<b>885</b>
Abutment dimensions .....	885
Raceways on shafts and in housings .....	885
<b>Designation system</b> .....	<b>886</b>
<b>Product table</b>	
<b>11.1</b> Cylindrical roller thrust bearings .....	888

# 11 Cylindrical roller thrust bearings

## More information

<b>General bearing knowledge</b> . . . . .	<b>17</b>
<b>Bearing selection process</b> . . . . .	<b>59</b>
Lubrication . . . . .	109
Bearing interfaces . . . . .	139
Sealing, mounting and dismounting . . . . .	193

*SKF bearing maintenance  
handbook* ISBN 978-91-978966-4-1

SKF cylindrical roller thrust bearings (fig. 1) are designed to accommodate heavy axial loads and impact loads. They must not be subjected to any radial load. The bearings are very stiff and require little axial space.

## Bearing features

- **Separable design**  
Shaft washer, housing washer, cylindrical roller and cage thrust assembly can be mounted separately.
- **Extended bearing service life**  
To prevent stress peaks, the roller ends are relieved slightly to modify the line contact between the raceway and rollers.



# Designs and variants

SKF supplies cylindrical roller thrust bearings in different series (fig. 2):

- 811 and 812 series bearings with one row of rollers  
They are mainly used in applications where thrust ball bearings do not have sufficient load carrying capacity.
- 893 and 894 series bearings with two rows of rollers

## Single direction bearings

As standard, cylindrical roller thrust bearings are available as single direction bearings (fig. 2) and can accommodate axial loads in one direction only.

## Double direction bearings

- can accommodate axial loads in both directions
- can be created by combining two cylindrical roller and cage thrust assemblies and two bearing washers with an intermediate washer  
Depending on the design, an intermediate washer can be shaft or housing centred (fig. 3).

Intermediate washers must have the same surface finish and hardness as bearing washers. SKF does not supply intermediate washers, but provides material specifications and dimensional data on request.

For additional information, refer to *Design considerations*, page 885.

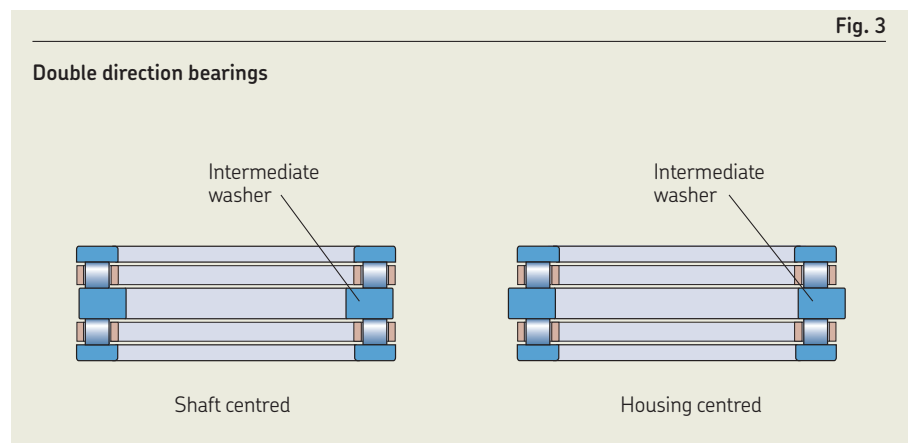
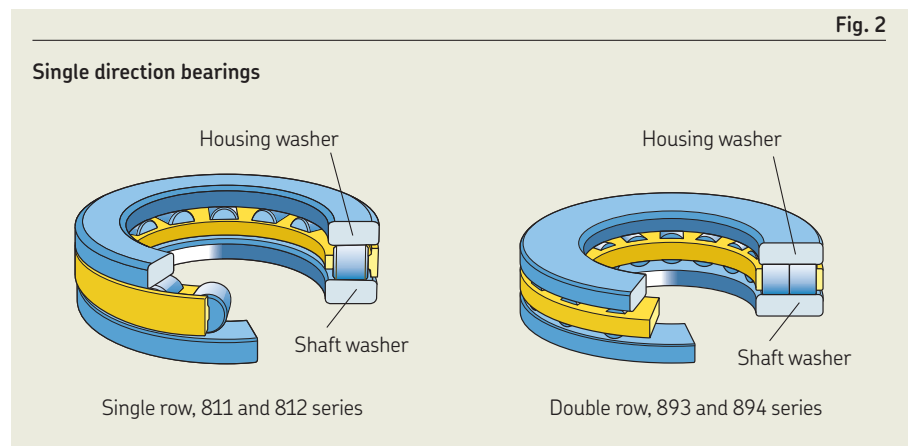

## Cylindrical roller and cage thrust assemblies

- are identified by the prefix K (fig. 4)
- can accommodate axial loads in one direction only
- can be combined with washers in the WS, GS and LS series (*Bearing washers*)
- can be used without washers in applications where:
  - adjacent components can serve as raceways
  - bearing arrangements with a low axial section height are required

## Bearing washers

SKF can also supply the components of cylindrical roller thrust bearings also separately. Additional to cylindrical roller and cage thrust assemblies the included bearing washers (fig. 5) are listed in the [product table, page 888](#).

### Shaft washers

- are identified by the prefix WS
- are made of hardened carbon chromium bearing steel
- have a precision-ground raceway surface
- have a ground bore

### Housing washers

- are identified by the prefix GS
- are made of hardened carbon chromium bearing steel
- have a precision-ground raceway surface
- have a ground outside surface

SKF recommends using both of these washers in high-speed applications where accurate centring of the bearing washers is required.

### LS series universal washers

- can be used as both shaft or housing washers for bearings in the 811 series
- are used for applications where accurate centring of the bearing washers is not necessary
- are used where low speeds are involved

For additional information about LS series washers, refer to *Needle roller thrust bearings*, [page 895](#).

Fig. 4

Cylindrical roller and cage thrust assembly

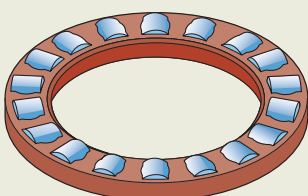
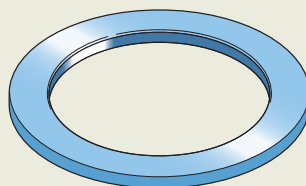
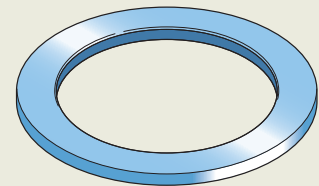

Fig. 5

Bearing washers



Shaft washer





Housing washer

# Cages

SKF cylindrical roller thrust bearings are fitted with one of the cages shown in [table 1](#).

When used at high temperatures, some lubricants can have a detrimental effect on polyamide cages. For additional information about the suitability of cages, refer to *Cages*, [page 187](#).

Table 1		
Cages for cylindrical roller thrust bearings		
		
<b>Materials</b>	Glass fibre reinforced PA66	Machined brass
<b>Suffix</b>	TN	M

## Bearing data

<b>Dimension standards</b>	Boundary dimensions: ISO 104
<b>Tolerances</b>	Normal Check availability of P5 tolerance class for larger bearings Values: ISO 199 ( <a href="#">table 10, page 46</a> )
For additional information → <a href="#">page 35</a>	Except for components ( <a href="#">table 2, page 882</a> ): <ul style="list-style-type: none"> <li>• Values (<a href="#">table 3, page 883</a>)</li> <li>• Variation of gauge lot diameter of the rollers: ISO 12297</li> </ul>
<b>Permissible misalignment</b>	Cannot tolerate any misalignment.

Tolerances for cylindrical roller thrust bearing components

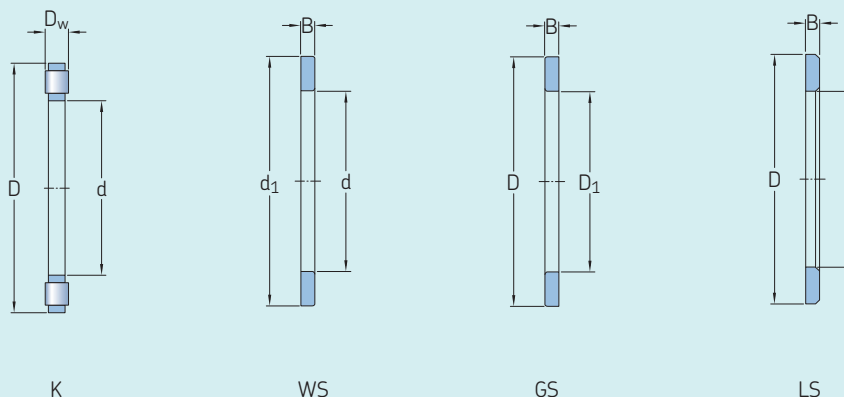

Bearing component	Tolerance, tolerance class <sup>1)</sup> , standard	
Dimensions		
<b>Cylindrical roller and cage thrust assemblies, K</b>		
Bore diameter	d	E11
Outside diameter	D	a13
Roller diameter	D <sub>w</sub>	ISO 12297
<b>Shaft washers, WS</b>		
Bore diameter	d	Normal, ISO 199
Outside diameter	d <sub>1</sub>	–
Thickness	B	h11
Axial run-out	s <sub>i</sub>	Normal, ISO 199
<b>Housing washers, GS</b>		
Outside diameter	D	Normal, ISO 199
Bore diameter	D <sub>1</sub>	–
Thickness	B	h11
Axial run-out	s <sub>e</sub>	Normal, ISO 199
<b>Universal washers, LS</b>		
Bore diameter	d	E12
Outside diameter	D	a12
Thickness	B	h11
Axial run-out	s <sub>i</sub>	Normal, ISO 199

<sup>1)</sup> The envelope requirement (symbol  $\text{E}$  from ISO 14405-1) is not shown but applies to all tolerance classes.

Table 3

ISO tolerance classes

Nominal dimension		a12 <sup>Ⓔ</sup> Deviations		a13 <sup>Ⓔ</sup> Deviations		E11 <sup>Ⓔ</sup> Deviations		E12 <sup>Ⓔ</sup> Deviations		h11 <sup>Ⓔ</sup> Deviations	
>	≤	U	L	U	L	U	L	U	L	U	L
mm		μm		μm		μm		μm		μm	
-	3	-	-	-	-	-	-	-	-	0	-60
3	6	-	-	-	-	-	-	-	-	0	-75
6	10	-	-	-	-	-	-	-	-	0	-90
10	18	-	-	-	-	+142	+32	+212	+32	0	-110
18	30	-300	-510	-300	-630	+170	+40	+250	+40	0	-130
30	40	-310	-560	-310	-700	+210	+50	+300	+50	-	-
40	50	-320	-570	-320	-710	+210	+50	+300	+50	-	-
50	65	-340	-640	-340	-800	+250	+60	+360	+60	-	-
65	80	-360	-660	-360	-820	+250	+60	+360	+60	-	-
80	100	-380	-730	-380	-920	+292	+72	+422	+72	-	-
100	120	-410	-760	-410	-950	+292	+72	+422	+72	-	-
120	140	-460	-860	-460	-1 090	+335	+85	+485	+85	-	-
140	160	-520	-920	-520	-1 150	+335	+85	+485	+85	-	-
160	180	-580	-980	-580	-1 210	+335	+85	-	-	-	-
180	200	-660	-1 120	-660	-1 380	+390	+100	-	-	-	-
200	225	-	-	-740	-1 460	+390	+100	-	-	-	-
225	250	-	-	-820	-1 540	+390	+100	-	-	-	-
250	280	-	-	-920	-1 730	+430	+110	-	-	-	-
280	315	-	-	-1 050	-1 860	+430	+110	-	-	-	-
315	355	-	-	-1 200	-2 090	+485	+125	-	-	-	-
355	400	-	-	-1 350	-2 240	+485	+125	-	-	-	-
400	450	-	-	-1 500	-2 470	+535	+135	-	-	-	-
450	500	-	-	-1 650	-2 620	+535	+135	-	-	-	-
500	630	-	-	-1 900	-3 000	+585	+145	-	-	-	-
630	800	-	-	-2 100	-3 350	-	-	-	-	-	-

# Loads

<p><b>Minimum load</b></p> <p>For additional information → <a href="#">page 106</a></p>	$F_{am} = 0,0005 C_0 + A \left( \frac{n}{1\,000} \right)^2$	<p><b>Symbols</b></p> <p>A minimum load factor (<a href="#">page 888</a>)                  C<sub>0</sub> basic static load rating [kN] (<a href="#">page 888</a>)                  F<sub>a</sub> axial load [kN]                  F<sub>am</sub> minimum axial load [kN]                  n rotational speed [r/min]</p>
<p><b>Equivalent dynamic bearing load</b></p> <p>For additional information → <a href="#">page 91</a></p>	$P = F_a$	<p>P equivalent dynamic bearing load [kN]                  P<sub>0</sub> equivalent static bearing load [kN]</p>
<p><b>Equivalent static bearing load</b></p> <p>For additional information → <a href="#">page 105</a></p>	$P_0 = F_a$	

## Temperature limits

The permissible operating temperature for cylindrical roller thrust bearings can be limited by:

- the dimensional stability of the bearing washers and rollers
- the cage
- the lubricant

Where temperatures outside the permissible range are expected, contact SKF.

## Bearing washers and rollers

The bearings are heat stabilized up to at least 120 °C (250 °F).

## Cages

Brass cages can be used at the same operating temperatures as the bearing washers and rollers. For temperature limits of polymer cages, refer to *Polymer cages*, [page 188](#).

## Lubricants

For temperature limits of SKF greases, refer to *Selecting a suitable SKF grease*, [page 116](#).  
 When using lubricants not supplied by SKF, temperature limits should be evaluated according to the SKF traffic light concept, [page 117](#).

## Permissible speed

The speed ratings in the [product table](#), [page 888](#) indicate:

- the **reference speed**, which enables a quick assessment of the speed capabilities from a thermal frame of reference
- the **limiting speed**, which is a mechanical limit that should not be exceeded unless the bearing design and the application are adapted for higher speeds

For additional information, refer to *Operating temperature and speed*, [page 130](#).



# Design considerations

## Abutment dimensions

Abutment dimensions should fulfill the following:

- Support surfaces in housings and on shafts should be at right angles to the shaft axis and provide uninterrupted support over the entire washer face.
- The abutment diameter on the shaft should be  $\geq d_{a\min}$  and in the housing  $\leq D_{a\max}$  (fig. 6). Values for  $d_{a\min}$  and  $D_{a\max}$  are listed in the [product table, page 888](#)
- Shafts and housings should be manufactured to suitable tolerance classes ([table 4](#)) to provide satisfactory radial guidance for the individual thrust bearing components.
  - Housing centred washers require a radial gap between the shaft and washer bore.
  - Shaft centred washers require a radial gap between the washer and the housing bore.

Cylindrical roller and cage thrust assemblies are generally centred radially by the shaft to reduce the circumferential speed at which the cage slides against the guiding surface. This is particularly important for higher-speed applications. The guiding surface should be ground.

## Raceways on shafts and in housings

- should have the same hardness, surface finish and axial run-out as a bearing washer, if the load carrying capacity of a cylindrical roller and cage thrust assembly is to be fully exploited
- should be designed using the dimensions  $E_a$  and  $E_b$  ([product table, page 888](#)), which take radial displacement of the roller set into consideration

For additional information, refer to *Raceways on shafts and in housings*, [page 179](#).

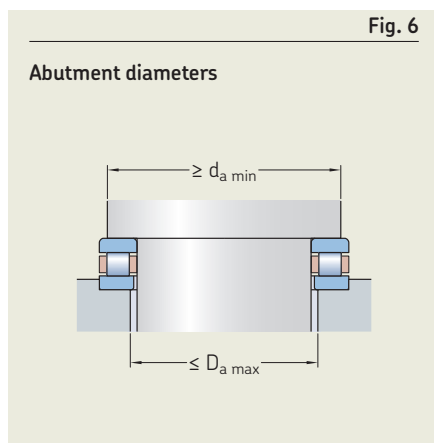

Table 4

### Shaft and housing tolerance classes

Bearing component	Prefix	Tolerance class <sup>1)</sup>	
		Shaft centred	Housing centred
Cylindrical roller and cage thrust assemblies	K	h8	–
Shaft washers	WS	h8	–
Housing washers	GS	–	H9

<sup>1)</sup> The envelope requirement (symbol  $\text{E}$  from ISO 14405-1) is not shown but applies to all tolerance classes.

# Designation system

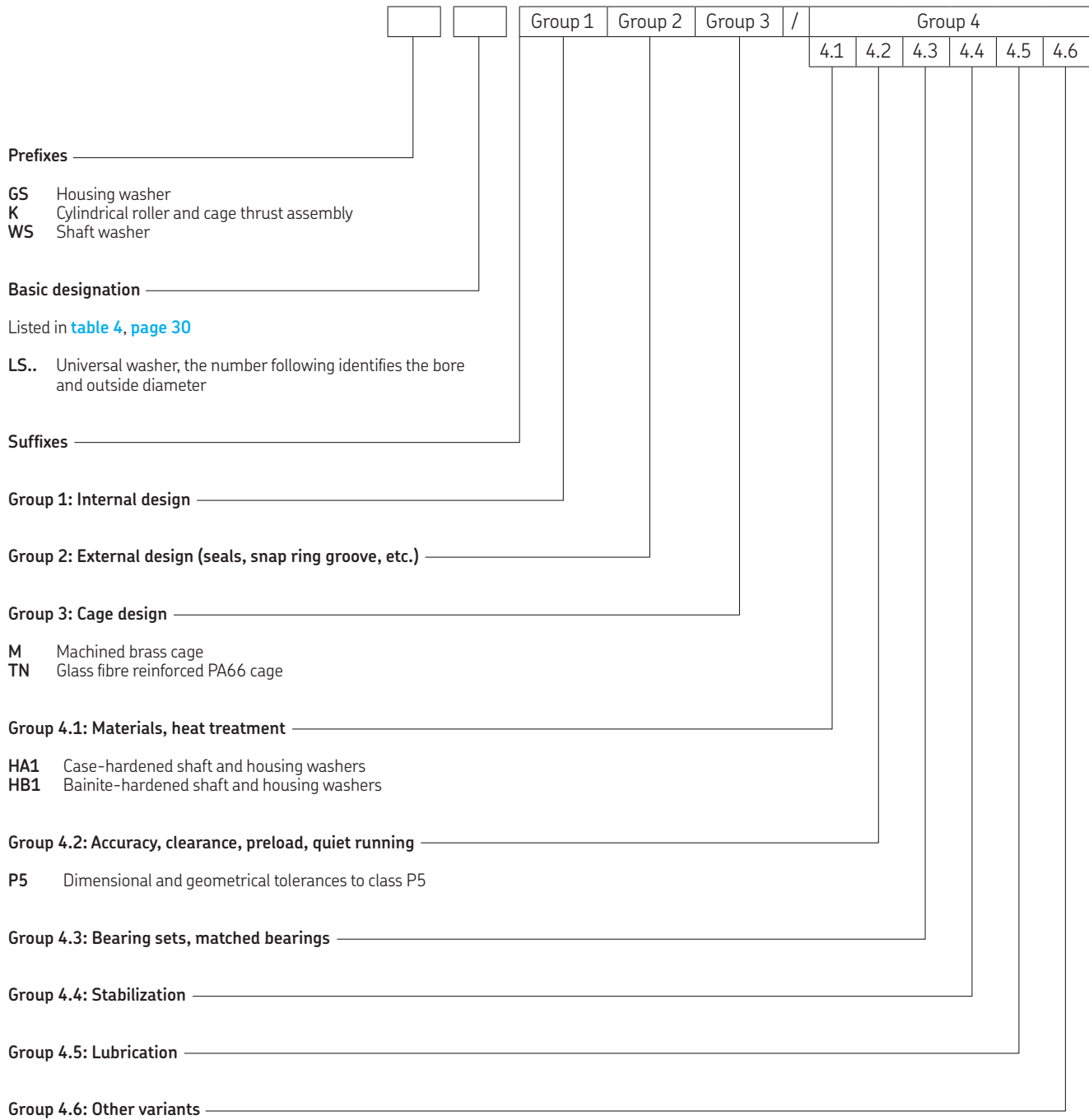



## 11.1 Cylindrical roller thrust bearings

d 15 – 75 mm

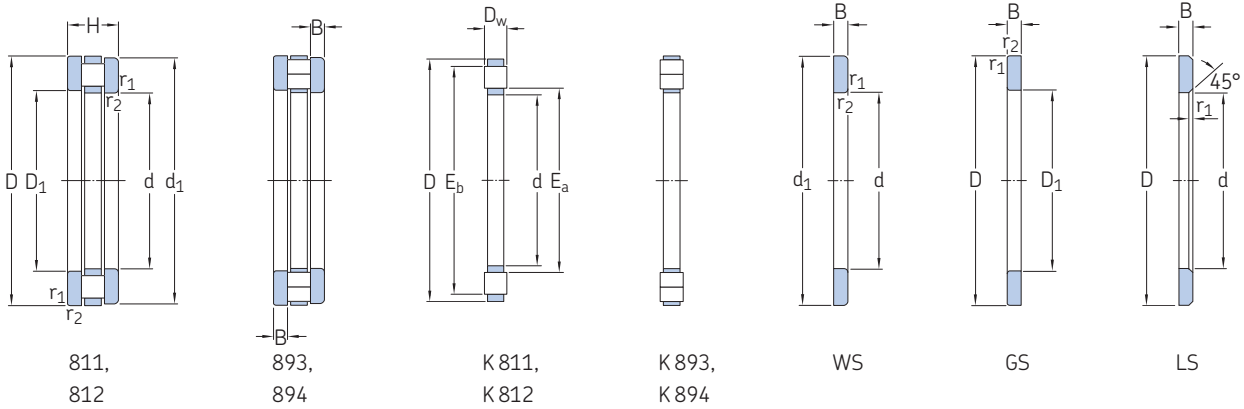

Principal dimensions					Basic load ratings		Fatigue load limit	Minimum load factor	Speed ratings		Mass	Designation
d	D	H	E <sub>a</sub>	E <sub>b</sub>	dynamic	static			Reference speed	Limiting speed		
mm					C	C <sub>0</sub>	P <sub>u</sub>	A	r/min		kg	-
15	28	9	16	27	11,2	27	2,45	0,000 058	4 300	8 500	0,024	► 81102 TN
17	30	9	18	29	12,2	31,5	2,85	0,000 079	4 300	8 500	0,027	► 81103 TN
20	35	10	21	34	18,6	48	4,65	0,00018	3 800	7 500	0,037	► 81104 TN
25	42	11	26	41	25	69,5	6,8	0,00039	3 200	6 300	0,053	► 81105 TN
30	47	11	31	46	27	78	7,65	0,00049	3 000	6 000	0,057	► 81106 TN
	52	16	31	50	50	134	13,4	0,0014	2 400	4 800	0,12	► 81206 TN
35	52	12	36	51	29	93	9,15	0,00069	2 800	5 600	0,073	► 81107 TN
	62	18	39	58	62	190	19,3	0,0029	2 000	4 000	0,21	► 81207 TN
40	60	13	42	58	43	137	13,7	0,0015	2 400	5 000	0,11	► 81108 TN
	68	19	43	66	83	255	26,5	0,0052	1 900	3 800	0,25	► 81208 TN
	78	22	44	77	95	365	36,5	0,011	2 000	4 000	0,48	89308 TN
45	65	14	47	63	45	153	15,3	0,0019	2 200	4 500	0,13	► 81109 TN
	73	20	48	70	83	255	26,5	0,0052	1 800	3 600	0,29	► 81209 TN
50	70	14	52	68	47,5	166	16,6	0,0022	2 200	4 300	0,14	► 81110 TN
	78	22	53	75	91,5	300	31	0,0072	1 700	3 400	0,36	► 81210 TN
55	78	16	57	77	69,5	285	29	0,0065	1 900	3 800	0,23	► 81111 TN
	90	25	59	85	122	390	40	0,012	1 400	2 800	0,57	► 81211 TN
60	85	17	62	82	80	300	30,5	0,0072	1 800	3 600	0,27	► 81112 TN
	95	26	64	91	137	465	47,5	0,017	1 400	2 800	0,65	► 81212 TN
	110	30	66	108	153	640	65,5	0,033	1 400	2 800	1,25	89312 TN
65	90	18	67	87	83	320	32,5	0,0082	1 700	3 400	0,31	► 81113 TN
	100	27	69	96	140	490	50	0,019	1 300	2 600	0,72	► 81213 TN
	115	30	71	113	153	640	65,5	0,033	1 400	2 800	1,35	89313 TN
70	95	18	72	92	86,5	345	34,5	0,0095	1 700	3 400	0,33	► 81114 TN
	105	27	74	102	146	530	55	0,022	1 300	2 600	0,77	► 81214 TN
	125	34	76	123	186	800	81,5	0,05	1 300	2 600	1,8	89314 TN
75	100	19	78	97	83	335	34	0,009	1 600	3 200	0,39	► 81115 TN
	110	27	79	106	137	490	50	0,019	1 200	2 400	0,8	► 81215 TN

► Popular item

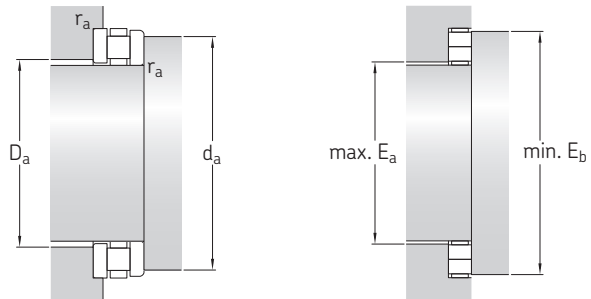

Dimensions						Abutment and fillet dimensions			Designation of components			
d	d <sub>1</sub> ≈	D <sub>1</sub> ≈	B	D <sub>w</sub>	r <sub>1,2</sub> min.	d <sub>a</sub> min.	D <sub>a</sub> max.	r <sub>a</sub> max.	Cylindrical roller and cage thrust assembly	Shaft washer	Housing washer	Universal washer
mm						mm			-			
15	28	16	2,75	3,5	0,3	27	16	0,3	K 81102 TN	WS 81102	GS 81102	LS 1528
17	30	18	2,75	3,5	0,3	29	18	0,3	K 81103 TN	WS 81103	GS 81103	LS 1730
20	35	21	2,75	4,5	0,3	34	21	0,3	K 81104 TN	WS 81104	GS 81104	LS 2035
25	42	26	3	5	0,6	41	26	0,6	K 81105 TN	WS 81105	GS 81105	LS 2542
30	47	32	3	5	0,6	46	31	0,6	K 81106 TN	WS 81106	GS 81106	LS 3047
	52	32	4,25	7,5	0,6	50	31	0,6	K 81206 TN	WS 81206	GS 81206	-
35	52	37	3,5	5	0,6	51	36	0,6	K 81107 TN	WS 81107	GS 81107	LS 3552
	62	37	5,25	7,5	1	58	39	1	K 81207 TN	WS 81207	GS 81207	-
40	60	42	3,5	6	0,6	58	42	0,6	K 81108 TN	WS 81108	GS 81108	LS 4060
	68	42	5	9	1	66	43	1	K 81208 TN	WS 81208	GS 81208	-
	78	42	7,5	7	1	77	44	1	K 89308 TN	WS 89308	GS 89308	-
45	65	47	4	6	0,6	63	47	0,6	K 81109 TN	WS 81109	GS 81109	LS 4565
	73	47	5,5	9	1	70	48	1	K 81209 TN	WS 81209	GS 81209	-
50	70	52	4	6	0,6	68	52	0,6	K 81110 TN	WS 81110	GS 81110	LS 5070
	78	52	6,5	9	1	75	53	1	K 81210 TN	WS 81210	GS 81210	-
55	78	57	5	6	0,6	77	56	0,6	K 81111 TN	WS 81111	GS 81111	LS 5578
	90	57	7	11	1	85	59	1	K 81211 TN	WS 81211	GS 81211	-
60	85	62	4,75	7,5	1	82	62	1	K 81112 TN	WS 81112	GS 81112	LS 6085
	95	62	7,5	11	1	91	64	1	K 81212 TN	WS 81212	GS 81212	-
	110	62	10,5	9	1,1	108	67	1,1	K 89312 TN	WS 89312	GS 89312	-
65	90	67	5,25	7,5	1	87	67	1	K 81113 TN	WS 81113	GS 81113	LS 6590
	100	67	8	11	1	96	69	1	K 81213 TN	WS 81213	GS 81213	-
	115	67	10,5	9	1,1	113	72	1,1	K 89313 TN	WS 89313	GS 89313	-
70	95	72	5,25	7,5	1	92	72	1	K 81114 TN	WS 81114	GS 81114	LS 7095
	105	72	8	11	1	102	74	1	K 81214 TN	WS 81214	GS 81214	-
	125	72	12	10	1,1	123	78	1,1	K 89314 TN	WS 89314	GS 89314	-
75	100	77	5,75	7,5	1	97	78	1	K 81115 TN	WS 81115	GS 81115	LS 75100
	110	77	8	11	1	106	79	1	K 81215 TN	WS 81215	GS 81215	-



## 11.1 Cylindrical roller thrust bearings

d 80 – 180 mm

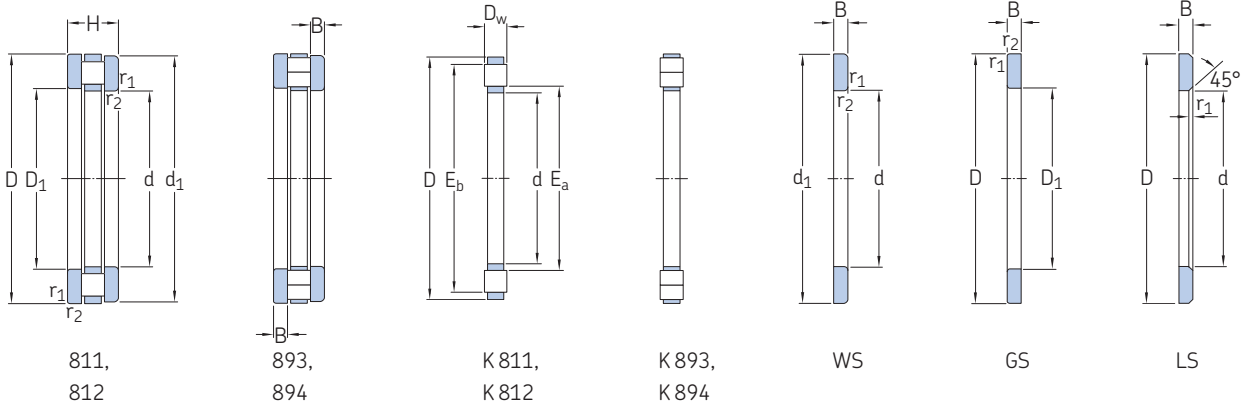

Principal dimensions					Basic load ratings		Fatigue load limit	Minimum load factor	Speed ratings		Mass	Designation
d	D	H	E <sub>a</sub>	E <sub>b</sub>	dynamic	static			Reference speed	Limiting speed		
mm					C	C <sub>0</sub>	P <sub>u</sub>	A	r/min		kg	-
80	105	19	83	102	81,5	335	34	0,009	1 500	3 000	0,4	▶ 81116 TN
	115	28	84	112	160	610	63	0,03	1 200	2 400	0,9	▶ 81216 TN
	140	36	86	137	240	1 060	108	0,09	1 200	2 400	2,35	89316 TN
	170	54	88	165	440	1 730	173	0,24	900	1 800	7,05	89416 M
85	110	19	87	108	88	365	37,5	0,011	1 500	3 000	0,42	▶ 81117 TN
	125	31	90	119	170	640	67	0,033	1 100	2 200	1,2	▶ 81217 TN
90	120	22	93	117	110	450	45,5	0,016	1 300	2 600	0,62	▶ 81118 TN
	135	35	95	129	232	865	90	0,06	1 000	2 000	1,75	▶ 81218 TN
100	135	25	104	131	156	630	62	0,032	1 200	2 400	0,95	▶ 81120 TN
	150	38	107	142	270	1 060	104	0,09	900	1 800	2,2	▶ 81220 TN
	170	42	109	166	300	1 370	132	0,15	950	1 900	4,55	89320 M
110	145	25	114	141	163	680	65,5	0,037	1 100	2 200	1,05	81122 TN
	160	38	117	152	260	1 000	98	0,08	850	1 700	2,3	▶ 81222 TN
	190	48	120	185	400	1 830	173	0,27	850	1 700	6,7	89322 M
120	155	25	124	151	170	735	68	0,043	1 100	2 200	1,1	▶ 81124 TN
	170	39	127	162	255	1 000	96,5	0,08	800	1 600	2,55	▶ 81224 TN
	210	54	132	205	510	2 360	216	0,45	750	1 500	9,45	89324 M
130	170	30	135	165	200	880	81,5	0,062	950	1 900	1,65	81126 TN
	190	45	137	181	380	1 460	137	0,17	700	1 400	4	▶ 81226 TN
140	180	31	145	175	208	930	85	0,069	900	1 800	1,9	▶ 81128 TN
	200	46	150	191	360	1 400	129	0,16	700	1 400	5,05	81228 M
150	190	31	155	185	212	1 000	88	0,08	850	1 700	2,2	▶ 81130 TN
	215	50	162	210	465	1 900	170	0,29	630	1 300	7,2	▶ 81230 M
160	200	31	165	195	216	1 020	90	0,083	850	1 700	2,1	▶ 81132 TN
	225	51	171	219	480	2 000	176	0,32	600	1 200	7,6	▶ 81232 M
	320	95	179	313	1 430	6 400	540	3,3	480	950	42	89432 M
170	215	34	176	209	285	1 340	118	0,14	800	1 600	2,4	▶ 81134 TN
	240	55	184	233	540	2 280	200	0,42	560	1 100	9,3	▶ 81234 M
	340	103	191	333	1 600	7 200	600	4,15	430	850	52	89434 M
180	225	34	185	219	270	1 270	110	0,13	750	1 500	3,7	▶ 81136 M
	250	56	194	243	550	2 400	204	0,46	560	1 100	9,95	81236 M
	360	109	200	351	1 760	8 000	655	5,1	400	800	60	89436 M

▶ Popular item

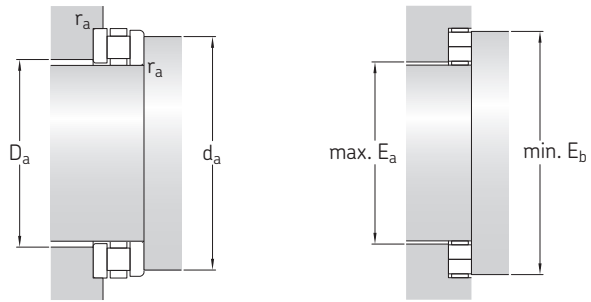

Dimensions					Abutment and fillet dimensions			Designation of components				
d	d <sub>1</sub> ≈	D <sub>1</sub> ≈	B	D <sub>w</sub>	r <sub>1,2</sub> min.	d <sub>a</sub> min.	D <sub>a</sub> max.	r <sub>a</sub> max.	Cylindrical roller and cage thrust assembly	Shaft washer	Housing washer	Universal washer
mm						mm			-			
80	105	82	5,75	7,5	1	102	83	1	K 81116 TN	WS 81116	GS 81116	LS 80105
	115	82	8,5	11	1	112	84	1	K 81216 TN	WS 81216	GS 81216	-
	140	82	12,5	11	1,5	137	88	1,5	K 89316 TN	WS 89316	GS 89316	-
	170	83	18	18	2,1	166	89	2,1	K 89416 M	WS 89416	GS 89416	-
85	110	87	5,75	7,5	1	108	87	1	K 81117 TN	WS 81117	GS 81117	LS 85110
	125	88	9,5	12	1	119	90	1	K 81217 TN	WS 81217	GS 81217	-
90	120	92	6,5	9	1	117	93	1	K 81118 TN	WS 81118	GS 81118	LS 90120
	135	93	10,5	14	1,1	129	95	1,1	K 81218 TN	WS 81218	GS 81218	-
100	135	102	7	11	1	131	104	1	K 81120 TN	WS 81120	GS 81120	LS 100135
	150	103	11,5	15	1,1	142	107	1,1	K 81220 TN	WS 81220	GS 81220	-
	170	103	14,5	13	1,5	167	109	1,5	K 89320 M	WS 89320	GS 89320	-
110	145	112	7	11	1	141	114	1	K 81122 TN	WS 81122	GS 81122	LS 110145
	160	113	11,5	15	1,1	152	117	1,1	K 81222 TN	WS 81222	GS 81222	-
	190	113	16,5	15	2	186	120	2	K 89322 M	WS 89322	GS 89322	-
120	155	122	7	11	1	151	124	1	K 81124 TN	WS 81124	GS 81124	LS 120155
	170	123	12	15	1,1	162	127	1,1	K 81224 TN	WS 81224	GS 81224	-
	210	123	18,5	17	2,1	206	130	2,1	K 89324 M	WS 89324	GS 89324	-
130	170	132	9	12	1	165	135	1	K 81126 TN	WS 81126	GS 81126	LS 130170
	187	133	13	19	1,5	181	137	1,5	K 81226 TN	WS 81226	GS 81226	-
140	178	142	9,5	12	1	175	145	1	K 81128 TN	WS 81128	GS 81128	LS 140180
	197	143	13,5	19	1,5	191	147	1,5	K 81228 M	WS 81228	GS 81228	-
150	188	152	9,5	12	1	185	155	1	K 81130 TN	WS 81130	GS 81130	LS 150190
	212	153	14,5	21	1,5	211	158	1,5	K 81230 M	WS 81230	GS 81230	-
160	198	162	9,5	12	1	195	165	1	K 81132 TN	WS 81132	GS 81132	LS 160200
	222	163	15	21	1,5	220	168	1,5	K 81232 M	WS 81232	GS 81232	-
	320	164	31,5	32	5	315	179	5	K 89432 M	WS 89432	GS 89432	-
170	213	172	10	14	1,1	209	176	1,1	K 81134 TN	WS 81134	GS 81134	-
	237	173	16,5	22	1,5	235	180	1,5	K 81234 M	WS 81234	GS 81234	-
	340	174	34,5	34	5	335	191	5	K 89434 M	WS 89434	GS 89434	-
180	222	183	10	14	1,1	219	185	1,1	K 81136 M	WS 81136	GS 81136	-
	247	183	17	22	1,5	245	190	1,5	K 81236 M	WS 81236	GS 81236	-
	360	184	36,5	36	5	353	203	5	K 89436 M	WS 89436	GS 89436	-



## 11.1 Cylindrical roller thrust bearings

d 190 – 320 mm

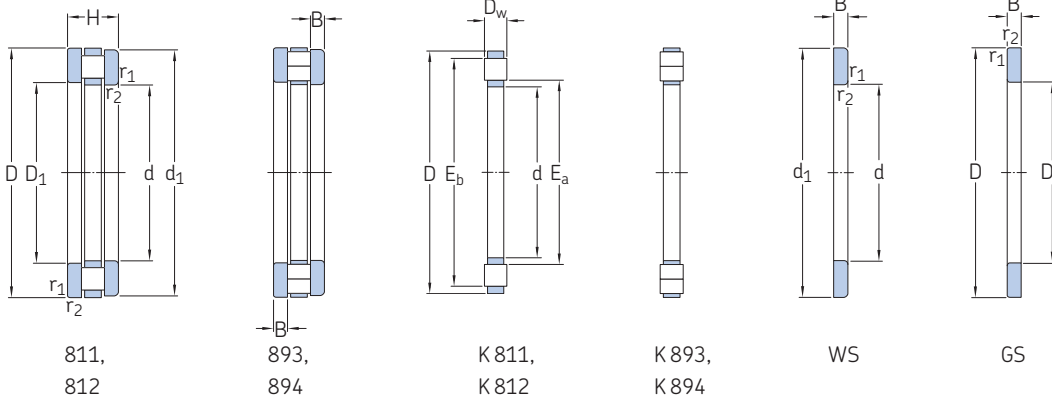

Principal dimensions			Basic load ratings		Fatigue load limit	Minimum load factor	Speed ratings		Mass	Designation		
d	D	H	dynamic	static			Reference speed	Limiting speed				
mm					C	C <sub>0</sub>	P <sub>u</sub>	A	r/min		kg	–
190	240	37	197	233	310	1 460	125	0,17	700	1 400	4,75	▶ 81138 M 81238 M 89438 M
	270	62	205	263	695	2 900	250	0,67	500	1 000	12	
	380	115	212	371	1 960	9 000	720	6,5	380	750	65,5	
200	250	37	206	243	310	1 500	125	0,18	700	1 400	4,95	▶ 81140 M 81240 M 89440 M
	280	62	215	273	720	3 100	255	0,77	500	1 000	13,5	
	400	122	224	391	2 160	10 000	800	8	360	700	75	
220	270	37	226	263	335	1 700	137	0,23	670	1 300	5,2	▶ 81144 M 81244 M 89444 M
	300	63	236	294	750	3 350	275	0,9	480	950	15	
	420	122	244	411	2 320	11 200	880	10	340	700	84,5	
240	300	45	248	296	475	2 450	196	0,48	560	1 100	8,45	▶ 81148 M 81248 M
	340	78	263	333	1 100	4 900	390	1,92	400	800	22	
260	320	45	268	316	490	2 600	200	0,54	530	1 100	9,1	▶ 81152 M 81252 M
	360	79	281	351	1 140	5 300	415	2,25	380	750	27	
280	350	53	288	346	680	3 550	275	1	480	950	12,5	81156 M
300	380	62	315	373	850	4 400	335	1,55	430	850	19,5	81160 M 81260 M
	420	95	329	412	1 530	7 200	540	4,1	320	630	43	
320	400	63	334	394	880	4 650	345	1,73	400	800	20,5	81164 M

▶ Popular item



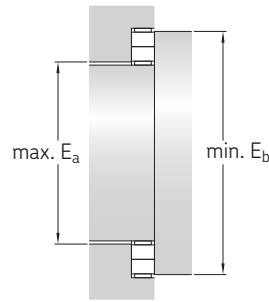
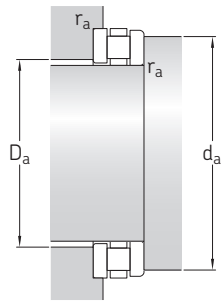

Dimensions					Abutment and fillet dimensions			Designation of components				
d	d <sub>1</sub> ≈	D <sub>1</sub> ≈	B	D <sub>w</sub>	r <sub>1,2</sub> min.	d <sub>a</sub> min.	D <sub>a</sub> max.	r <sub>a</sub> max.	Cylindrical roller and cage thrust assembly	Shaft washer	Housing washer	Universal washer
mm						mm			–			
190	237	193	11	15	1,1	233	197	1,1	K 81138 M	WS 81138	GS 81138	–
	267	194	18	26	2	265	200	2	K 81238 M	WS 81238	GS 81238	–
	380	195	38,5	38	5	373	214	5	K 89438 M	WS 89438	GS 89438	–
200	247	203	11	15	1,1	243	206	1,1	K 81140 M	WS 81140	GS 81140	–
	277	204	18	26	2	275	210	2	K 81240 M	WS 81240	GS 81240	–
	400	205	41	40	5	393	226	5	K 89440 M	WS 89440	GS 89440	–
220	267	223	11	15	1,1	263	226	1,1	K 81144 M	WS 81144	GS 81144	–
	297	224	18,5	26	2	296	230	2	K 81244 M	WS 81244	GS 81244	–
	420	225	41	40	6	413	246	6	K 89444 M	WS 89444	GS 89444	–
240	297	243	13,5	18	1,5	296	248	1,5	K 81148 M	WS 81148	GS 81148	–
	335	244	23	32	2,1	335	261	2,1	K 81248 M	WS 81248	GS 81248	–
260	317	263	13,5	18	1,5	316	268	1,5	K 81152 M	WS 81152	GS 81152	–
	355	264	23,5	32	2,1	353	280	2,1	K 81252 M	WS 81252	GS 81252	–
280	347	283	15,5	22	1,5	346	288	1,5	K 81156 M	WS 81156	GS 81156	–
300	376	304	18,5	25	2	373	315	2	K 81160 M	WS 81160	GS 81160	–
	415	304	28,5	38	3	413	328	3	K 81260 M	WS 81260	GS 81260	–
320	396	324	19	25	2	394	334	2	K 81164 M	WS 81164	GS 81164	–

